



LR24

mid-size line-array module

user's manual

Featured models:
LR24

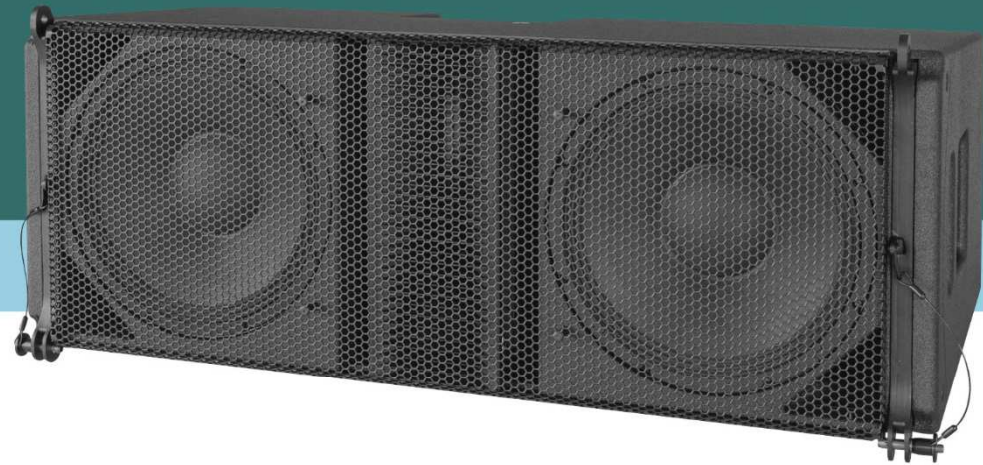

evolutionary audio solutions™

Table of contents

1	Introduction	3
2	Important safety instructions and precautions	4
3	Installation	5
4	Rigging components	6
5	Array configurations	10
6	Service and support	21
7	CE declaration of conformity	23

1. Introduction

Dear customer,

Congratulations on your purchase of an Alcons Audio LR24 line array loudspeaker and thank you for your confidence in Alcons products. We are very honoured to welcome you to the growing family of Alcons ambassadors!

For your safety, please read the Important safety instructions and the precautions section before rigging a loudspeaker array.

General features

The LR24 has the following features:

12" pro-ribbon HF section with exceptional intelligibility and "throw".

Non-compressed 1:1 HiFi-quality sound reproduction.

Maximum dynamic headroom reserve with up to 90% less distortion.

Intuitive predictable linear response behavior and identical tonal balance at any SPL.

A unique seamless arrayability up to/beyond 20kHz.

Fully coherent and symmetric pattern control in horizontal and vertical plane.

SIS™ Pre-wired for very high system damping and further reduced distortion.

All Neodymium drivers for excellent performance-to-weight ratio.

LR24 rigging features

The rigging system enables angle-setting on the cabinets without lifting the array, resulting in safer and faster set-up with minimal handling. The unique, patent-pending flying system facilitates both compressed and non-compressed suspension. It has a WLL of 24 cabinets under 10:1 safety.

Manual

This manual is written in a compact and easy readable way. You can contact Alcons Audio for more in-depth information on different items or situations



2. Important safety instructions and precautions

Read this manual

1. Follow all safety instructions as well as the warning messages.
2. Never incorporate equipment or accessories not approved by Alcons Audio.
3. Read all the related product information before using the system.
4. Work with qualified personnel for rigging the system.
5. Installation should only be carried out by qualified personnel who are familiar with the rigging techniques and safety recommendations stated in this manual.
6. Ensure health and safety during installation and setup.
7. All persons must wear protective headgear and footwear at all times. Under no circumstances personnel is allowed to climb into a loudspeaker assembly.
8. Respect the Working Load Limit (WLL) of third party equipment.
9. Alcons Audio is not responsible for any rigging equipment and accessories provided by third party manufacturers. Verify that the Working Load Limit (WLL) of the suspension points, chain hoists and all additional hardware rigging accessories is respected.
10. Respect the maximum configurations and the recommended safety level.
11. For safety issue, respect the maximum configurations outlined in this manual. To check the conformity of any configuration in regards with the safety level recommended by Alcons Audio.
12. Be cautious when flying a loudspeaker array. Always verify that no one is standing underneath the loudspeaker array when it is being raised or lowered. As the array is being raised, check each individual element to make sure that it is securely fastened to the adjacent element.
13. Never leave the array unattended during the installation process. As a general rule Alcons Audio recommends the use of safety slings at all times.
14. Ensure that the surface is suitable for ground-stacking a loudspeaker array.
15. Do not stack the loudspeaker array on unstable ground or surface. If the array is stacked on a structure, platform, or stage, always check that the latter can support the total weight of the array. As a general rule, Alcons Audio recommends the use of safety straps at all times.
16. When a loudspeaker assembly is deployed in an open air environment, wind can produce dynamic stress to the rigging components and suspension points. If the wind force exceeds 6 Beaufort scale, lower down and/or secure the loudspeaker array.



The exclamation point within a triangle is intended to alert the user to the presence of important operating instructions in the literature accompanying the product.

3. Installation

Unpacking

Carefully open the shipping carton and inspect all the parts. Every Alcons product is thoroughly tested and inspected before leaving the factory and should arrive in perfect condition. If you find any damage, notify the shipping company immediately. Only you, the consignee, may initiate a claim for shipping damage. Be sure to save all packing materials for the carrier's inspection.

4. Rigging components

LR24 loudspeaker

- | | |
|-----------------------|--|
| 1) LR24 cabinet | LR24 cabinet (shown) |
| 2) Front coupler | Front couplers, lockable with quick release pin |
| 3) Bar handles | Handles in the cabinet ensure easy handling |
| 4) Pin angle setting | Pin determines the angle between the cabinets |
| 5) Angle arm + lever | Lever to turn the angle arm |
| 6) Signal input/ link | Input/ link for the audio signal |
| 7) Angle frame | This frame holds features for the angle setting and coupling |
| 8) Connection pin | Bottom Pin for connection to a lower cabinet |
| 9) Red 0° pin | Pin keeping the cabinets in a 0° position enabling angle setting in compression mode |

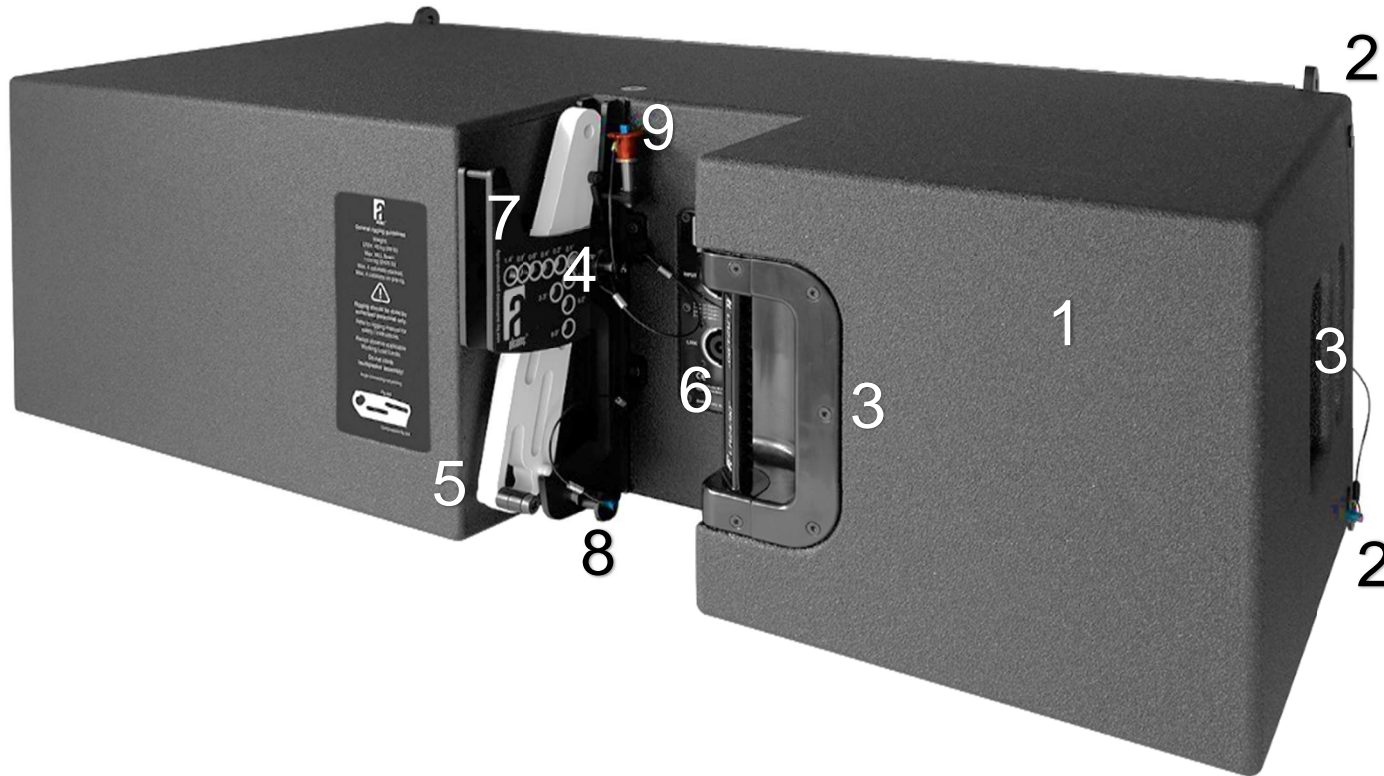

4. Rigging components

GRD24B

The GRD24B enables the LR24 line-array modules to be flown and ground stacked. The grid can be suspended from multiple hoist options on top of the grid or with the central “single pick-point” bar for smaller arrays (all points 14mm/0.55-in for 1,5T shackles). The GRD18B has a weight of 35 kg / 77 lb and is certified for 24 cabinets LR24

GRD28B

The GRD28B enables LR24 line-array modules to be flown or stacked together with LR28B. Please refer to the LR28 rigging manual.

GRD24EXTBR

This is an extension bar, which can be attached on top of the GRD24B, to extend the leverage capabilities of the GRD24B, with larger centre-of-gravity (COG) array off-sets.

With the GRD24EXTBR mounted at the front side of the GRD24B, the upward array tilt is extended; With the GRD24EXTBR mounted at the rear side of the GRD24B, the downward array tilt is extended. The front and rear holes measure 20mm/0.8-in to facilitate 3,25T shackles. Always use both quick release pins for the GRD24B/GRD24EXTBR connection.

PBFRML24

This frame is used as a pull-back device for compression style flying. The hoist point measures 20mm/0.8-in for a 3,25T shackle.

CNVB1824

This bracket is a transition frame to suspend a small LR18 array under a LR24 for down fill applications. It enables a maximum tilt angle of 8° between LR24 and LR18. CNVB1824 is certified for six (6) cabinets LR18.



4. Rigging components



PRRGL24

The LR24 is transported with 4 units on the PRRGL24 pre-rig dolly frame, facilitating curved or straight stacks. The dolly frame also enables a ground-stack configuration. With the optional detachable legs the tilt-angle can be adjusted. The LR24 is transported with 4 units on the PRRGL24 pre-rig dolly frame, facilitating curved or straight stacks. The dolly frame also enables a ground-stack configuration; With the optional detachable legs the tilt-angle can be adjusted.

STCKFTL24

Optional stack foot, mounted on a PRRGL24 corner



PRRGL24TOP

A detachable plateau can be mounted on top of a curved or straight stack. This can be used as a flat stowage plateau. The maximum load is 22 kg/ 55 lb. The pre-rig dollies can be placed on top of each other together with the plateaus.



4. Rigging components

Cabinet connections LR24

Array assembling can be done in two ways: Fly mode or Compression mode. This is determined by the available space, time or available parts.

There are 10 user selectable logarithmic angles, which can be determined by the Alcons Ribbon Calculator™ simulation program. The angles are suitable for both Fly and Compression mode array flying.

The angle lay-out is pictured below. The “P” indicates the position of the angle pin, when parking the angle arm.

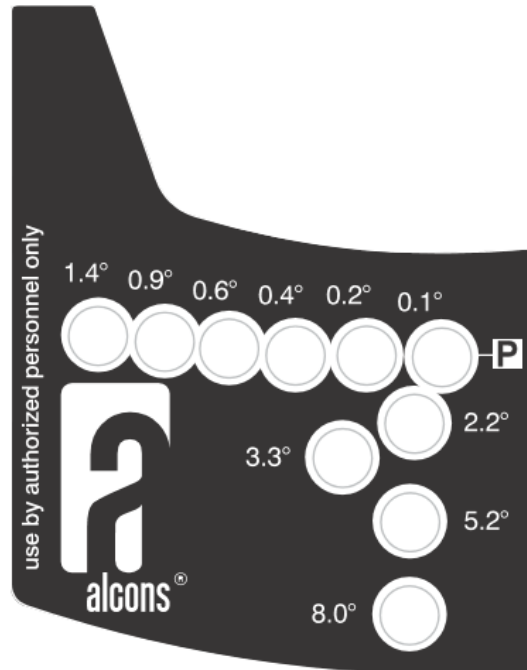

The picture on the right shows the angle frame(7), with the angle arm(5) in its parking position, locked by the angle pin (4). It has two slots for both modes.

The arm is fitted with a tab, to hold the arm when placing it into position.

The indication on the corner handle bar indicates the horizontal dispersion of the LR24 cabinet; 90° as shown, or 120°



5. Array configurations

GRD24B options

The GRD24B has multiple mounting options. The picture on the left shows the different pick-points for flying an array. The A1 & A2 marked points are the default hoist points.

It is also possible to use one pick point from the A1 linear pattern. Use it only for max. 12x LR24. Use two hoists at any time. This is safer and easier for array building

When hanging a 12-24 LR24 array with 2 hoist points, use the **outermost** front and rear A1 pick points.

In case of a permanent installation, combine points A1 and A2 for a stable 3 or 4-point hang. **Use 1,5T shackles at all times**

A3 indicates the mounting position of an angle inclinometer. It has a 4x $\varnothing 4\text{mm}$; 16.5mm x 108.8mm hole pattern for the Teqsas laser/ inclinometer.

A4 is a 20mm/0.8-in hole for a 3,25T shackle used in compression mode flying, or as a cable sling attachment.

The 2 holes A5 will hold the connection pin between the LR24 angle arm and GRD24B

A8 marks the removable angle arms which are used on the top connection points on the GRD24B and are pinned by G1. The arms are secured in their parking space with their locking pins and a small fastening knob.

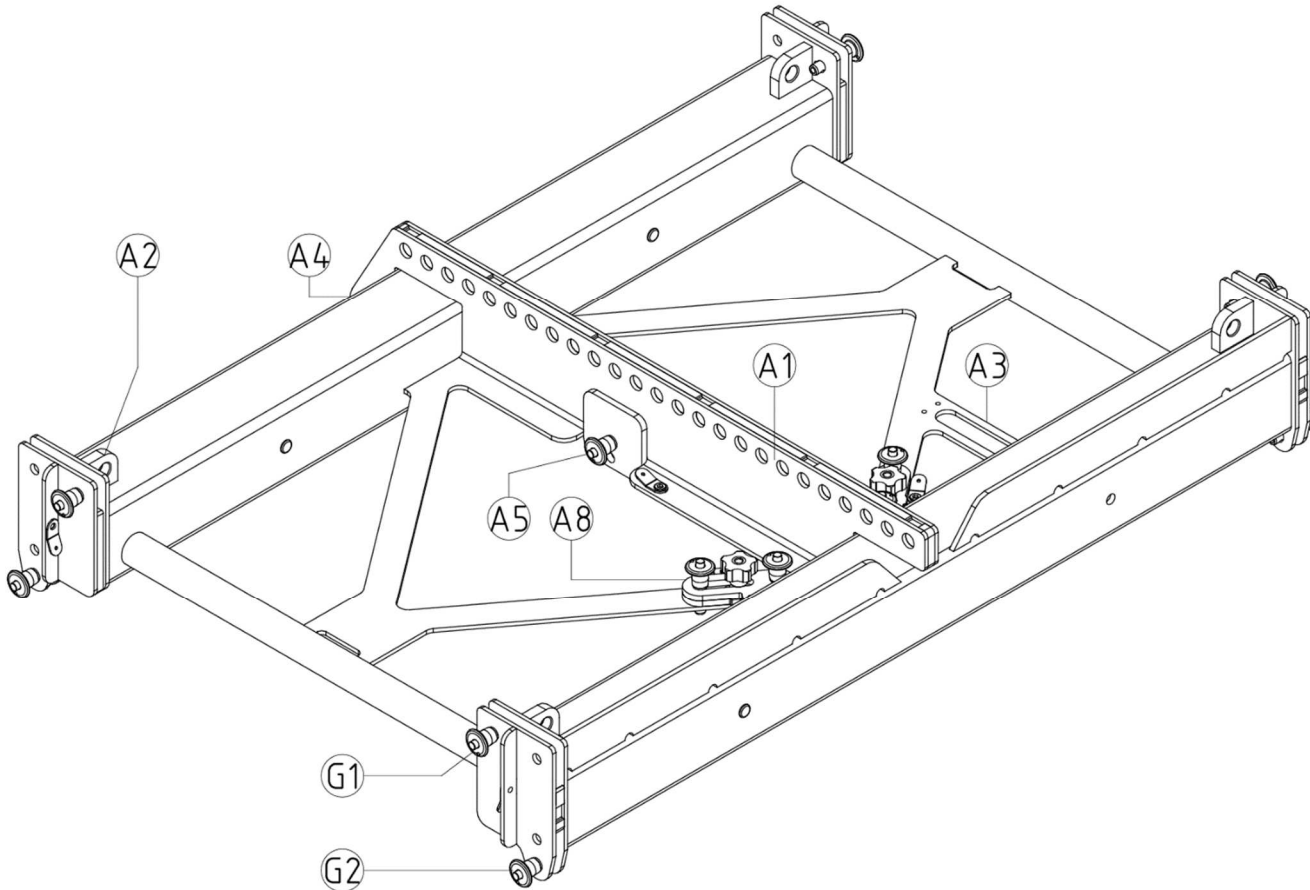

5. Array configurations

GRD24B options

The schematic picture below shows the possible array hang options a-d and stack arrangement e with LR24.

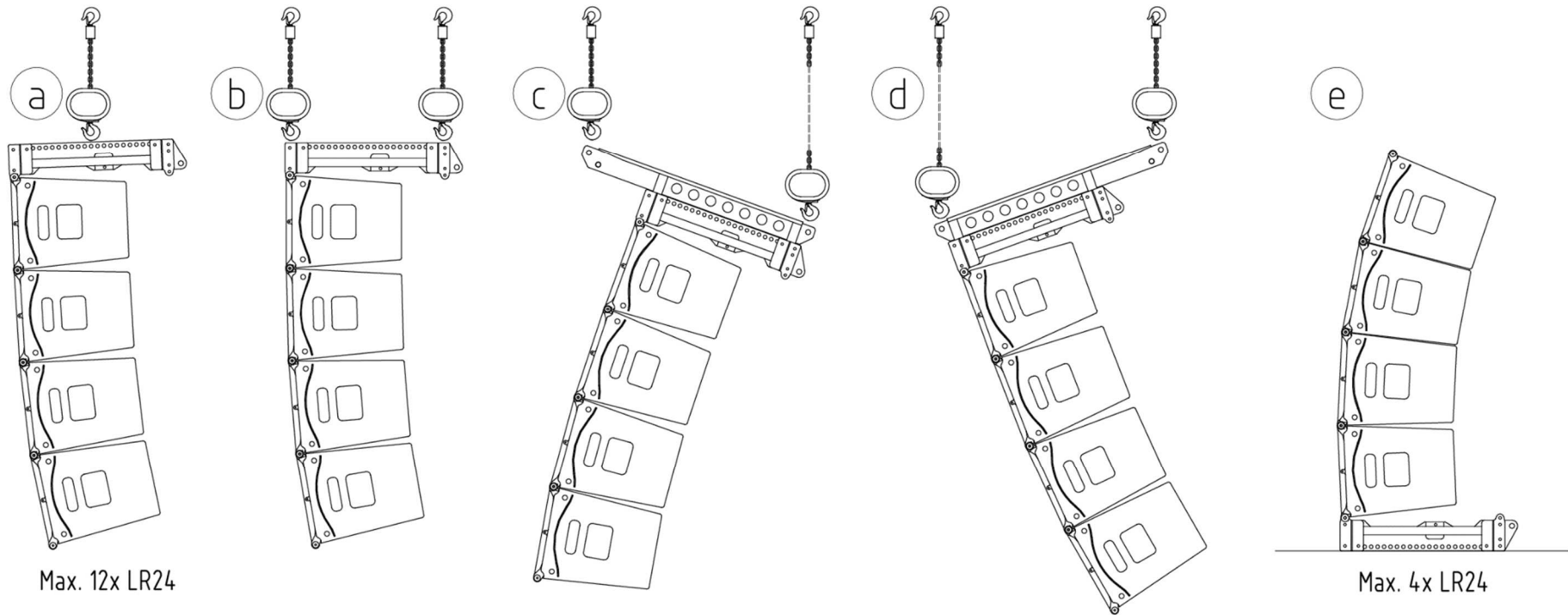

As stated earlier, the array angles can be determined through the Alcons Ribbon Calculator™ simulation program. When ground stacking (e), ensure that the centre of gravity is well within the grid's base area. single point hangs can be done but are not recommended with LR24 due to safety and array building complications.

5. Array configurations

LR24 transport and array building options

Curved pack/ Fly mode:

All LR24 cabinets are connected vertically in a curved pack. This saves building space and enables Pre-flight angle-setting. All red pins are stowed in their parking holes. The bottom cabinet is mounted to the PRRGL24 according to the picture on the right. Turn the triangular angle arm of the PRRGL24 in the upright position and pin with the locking pin. First, pin the top hole of the angle arm with the bottom cabinet connection pin (8). Then mount the front cabinet couplers (2) to the rear holes of each dual hole bracket.

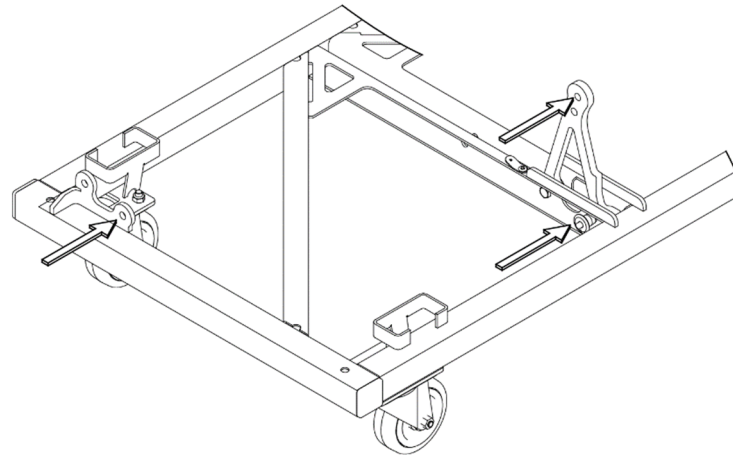

R+C P

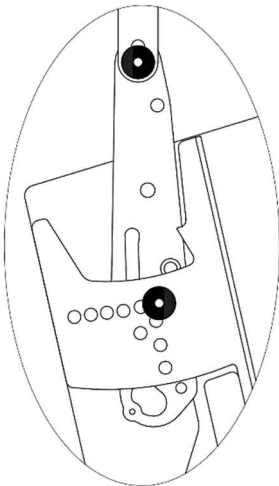

Mounting of the PRRGL24TOP on a curved pack

Mount the front brackets of the PRRGL24TOP with their rear holes to the top cabinet couplers. Both brackets are in between the cabinet couplers. Connect the cabinet angle bar (5) according to the picture on the left. It is also marked on the rear side of the PRRGL24TOP. Pin its locking pin through the angle arm in the bottom hole of the middle brackets of the PRRGL24TOP. Pin the angle pin (4) through the 'P' marked hole in the angle frame (7) and align it with the compression slot of the angle arm.

5. Array configurations

LR24 transport options

Straight pack/ compression mode:

All LR24 cabinets are connected vertically in a straight pack. This saves building space and enables pre-flight angle-setting. All red pins are placed in the angle arm hole. Except the angle arm of the top cabinet. The bottom cabinet is mounted to the PRRGL24 according to the picture right. Turn the triangular angle arm of the PRRGL24 in the short position. Do not use the locking pin. First, pin the top hole of the angle arm with the bottom cabinet connection pin (8). Then mount the front cabinet couplers (2) to the front holes of each dual hole bracket.

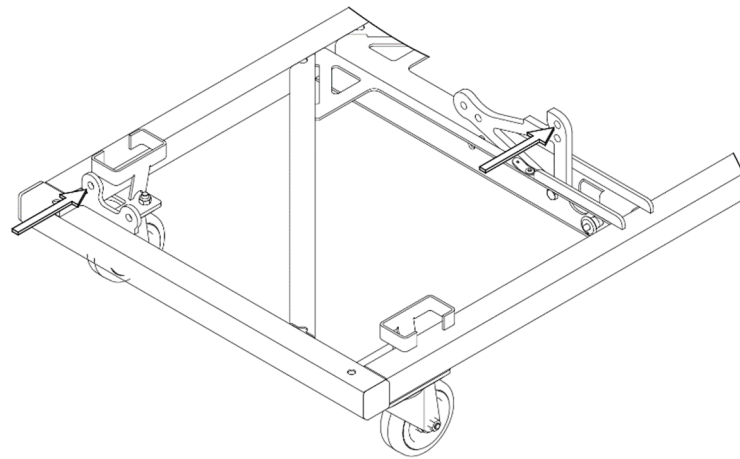

F + C 8

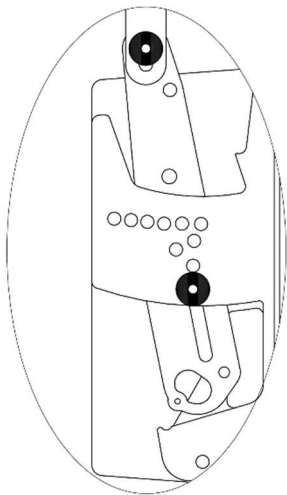

Mounting of the PRRGL24TOP on a straight pack

Mount the front brackets of the PRRGL24TOP with their front holes to the top cabinet couplers. Both brackets are on the inside of the cabinet couplers. Connect the cabinet angle bar (5) according to the picture on the left. It is also marked at the rear side of the PRRGL24TOP. Pin its locking pin with the angle arm in the bottom hole of the rear (middle) brackets of the PRRGL24TOP. Pin the angle pin (4) through the 'P' marked hole in the angle frame (7) and align it with the compression slot of the angle arm.

5. Array configurations

Fly mode array assembling and hoisting

The numbers in the text below, correspond with the LR24 loudspeaker overview pictured earlier.

Shown on the right depicts array building in Fly mode style. Shown with 2 hoists, 1x GRD24B and 8x LR24 cabinets.

Start removing the PRRGL24TOP plateaus. Attach the GRD24B to the first cabinet on the PRRGL24 pack (A). Keep all red pins in their parking slots. Pull the angle setting pins (4) out and set the correct angles using the Fly slot in the angle arm (5). These angles are determined by the Alcons Ribbon Calculator™ simulation program. Hoist the first pack from the pre-rig (B). Connect the necessary cabling to the signal input/ link (6) connectors. Use a sling from the grid for a tension free cable hang. Set the angles of the second pack and place it under the raised array and make a connection with both front couplers (2) (C). Connect the second set of cabling. Lower the hoists, and/ or pull the pre-rig backwards to close the rear opening between the cabinets. Then the rear connection of the angle arm(5) to the bottom cabinet pin (8) can be made (D). Raise the whole array and angle it to the desired positions.

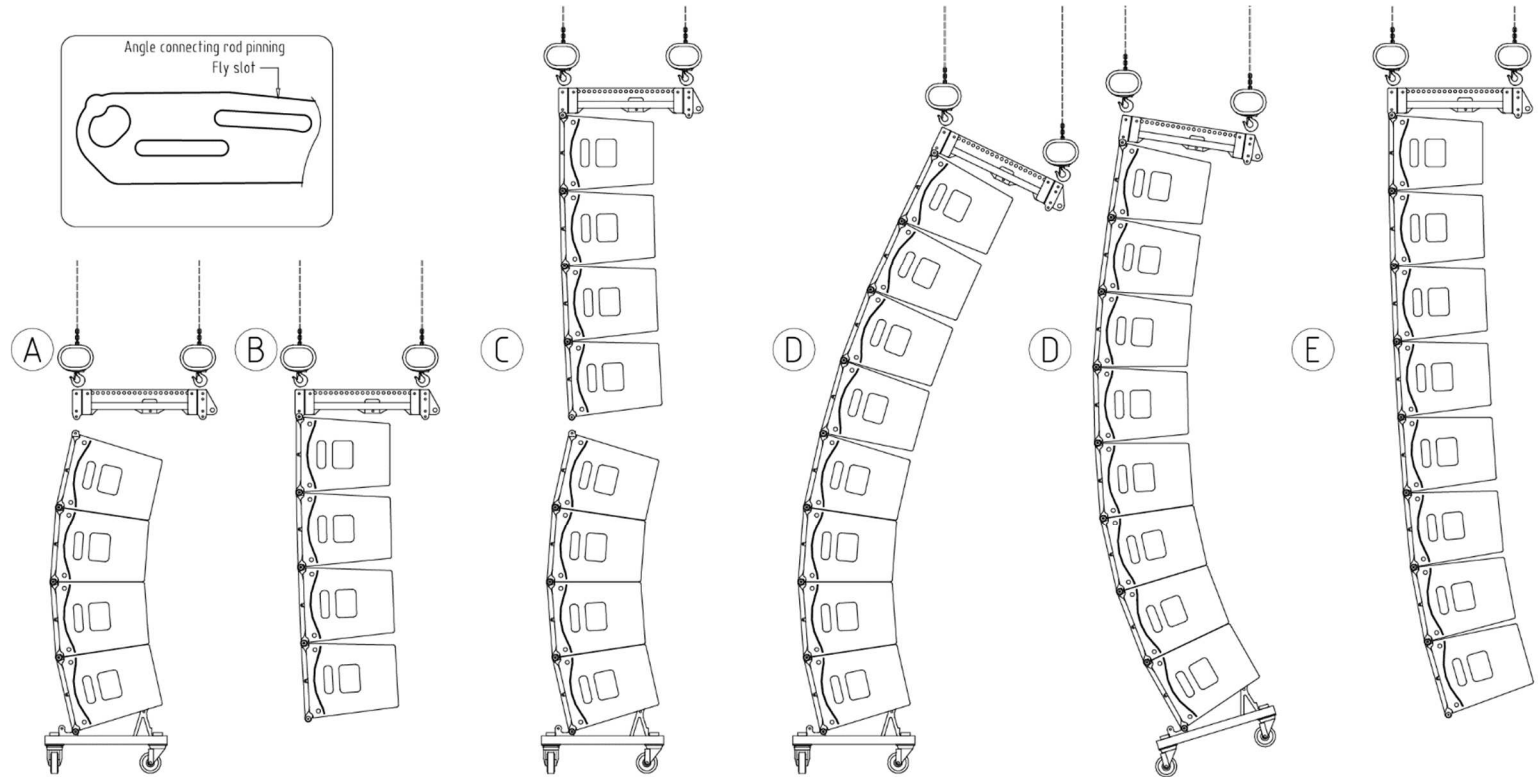

Use slow speed or speed-controllable chain hoists. Avoid any form of excessive dynamic loading to the array assembly



5. Array configurations

Storage PRRGL24 dollies

The dollies can be stored on top of each other, with or without the PRRGL24TOP plateaus. Turn the pre-rig angle arm to the middle locking pin position and pin it. The PRRGL24 can now be placed on top of each other. Turn all castor wheels inwards and place them inside the C-shaped holders on the frame.

When PRRGL24TOP's are used, place each plateau onto the dolly frame and pin it through the rear hole of the dual hole bracket

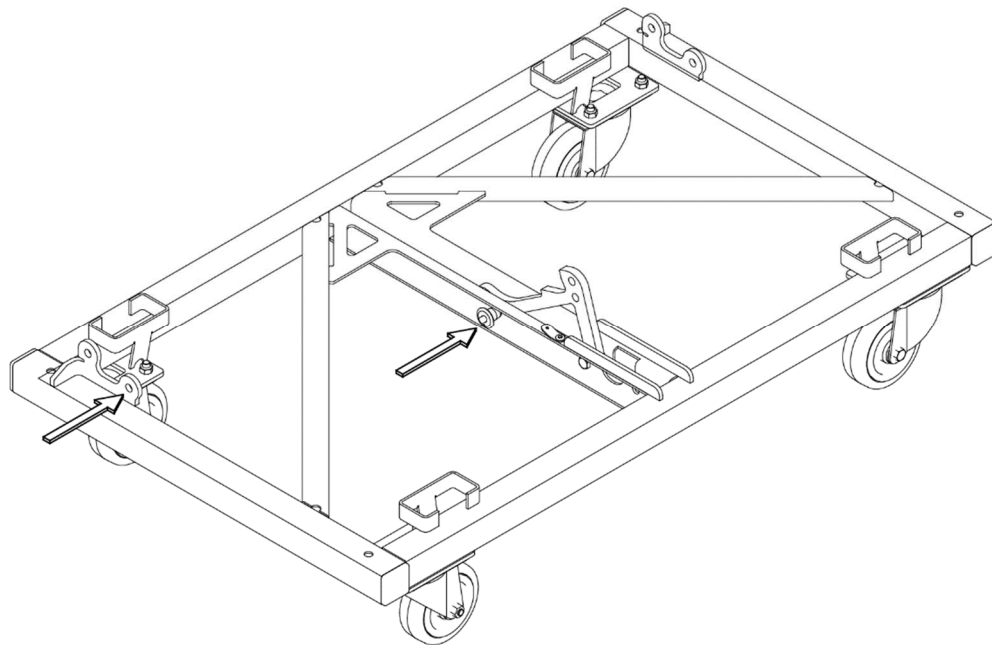

Landing the array in fly mode

Lower the array to working height and connect a pre-rig to the bottom cabinet with its angle arm first. Let the bottom pack compress and demount the rear connection. Undo all cabling, and turn the angle arms inwards and lock, if desired. Decouple the front couplers and lower the next pack onto the pre-rig. Turn the pre-rig angle arm in the upright position and lock it with its pin. Front cabinet couplers to the back holes of the dual hole bracket. Let the cabinets compress into a curved pack.

5. Array configurations

Compression mode array assembling and hoisting

This description features an 8 piece array connected to GRD24B

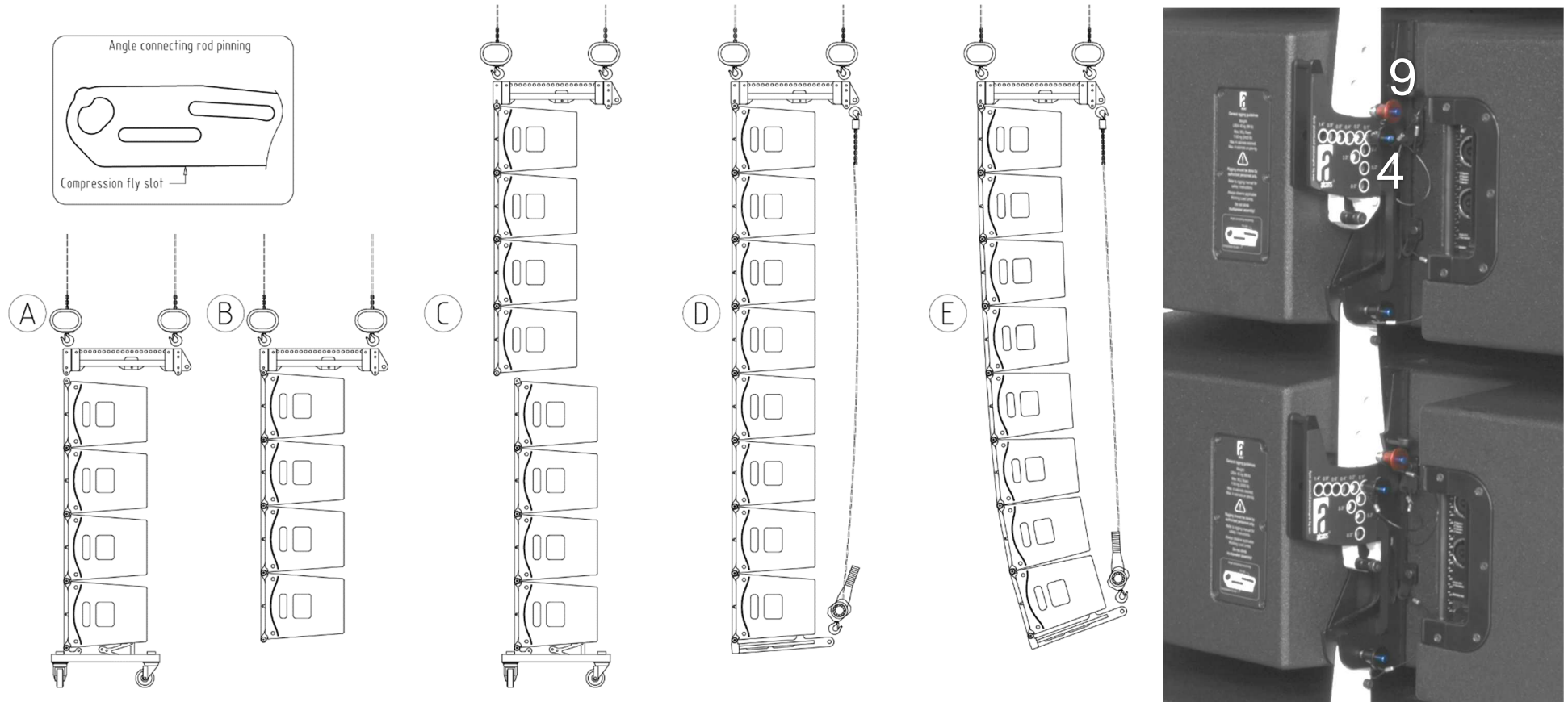

This flying option is best suited for small 4->12 pcs arrays. The cabinets are transported in a straight pack. The red buttoned pin (9) is crucial in this situation. It ensures that the cabinets (1) will stay in a 0° position. The angle arm can be adjusted while this pin is in position or "0° hole".

5. Array configurations

Take the top cabinet angle arm out of the transport position and put the red pin (9) in.
Choose the angles of all cabinets by aligning the angle pin (4) with the bottom compression fly slot in the angle arm (5).

The angle setting can be done at the warehouse or on-site. There will be pressure on the red pin (9) when adjusting the angle arm (5). A slight push/ tilt against the overlying cabinet will also help to ease this pressure.
When the first cabinets are ready, attach GRD24B to the top cabinet (A). Attach the audio cabling and use a hoist sling to take the weight of the speaker cables

Attach a manual **0,75T lever hoist, with overload protection**, from the bottom 3.25T shackle position on the GRD24B. Be sure to have sufficient chain length. Use an extra safety chain in combination with the lever hoist. **It is not allowed to use a motor hoist.**

Take the PRRGL24 off when the first pack is suspended. **Remove all the red buttoned 0° pins (9)** and place them in the rubber lined parking holes
Position the next PRRGL24 pack under the suspended array (C). Ensure that all angle adjustments are done.

Lower the suspended array to make the three point connection (front couplers + angle arm coupling). You can remove the top red 0° pin to make the back connection easier. When finished and the combined array is suspended in the air (D), pull out all red buttoned pins (9).

Continue this procedure until full array length is reached.

End with attaching the PBFRL24 under the lowest cabinet. Mount the frame onto the front couplers (2) and lock with their pins. Make the connection with the lower cabinet connecting pin (8) and lock it (D)

Start hoisting the (lever) hoist to set the cabinet angles (E). **This has to be done by an authorised person.** Stop when there is no more slack in the array. This can be checked by pushing the array back and forth and listening for any slack noises in the angle setting frames.



Do not over-compress the array, as this can cause damage to the suspension system !

After the compression stage, the angle of the entire array can now be adjusted. Use an angle inclinometer on the GRD24B.



5. Array configurations

Landing the array compression mode

De-compress the cabinets to 0° by releasing the tension of the lever hoist. The whole array should now be hanging vertical. Remove the PBFRL24 and attach the PRRGL24 pre-rig. **This is a two man job.** The pre-rig angle arm is not locked with its pin, but is connected directly to the bottom cabinet connection.

Put the red buttoned pins (12) into the angle arms of the first 4 piece array. Land the PRRGL28 and detach the (front and back) cabinet connection pins above the top no. 4 cabinet on the PRRGL28 and put them into their transport recesses . Continue this procedure for all other cabinets.



Use slow speed or speed-controllable chain hoists. Avoid any form of excessive dynamic loading to the array assembly

Using CNVB1824

Attach the CNVB1824 frame to the LR24 front couplers (2) and bottom connection pin (8). Make the angle adjustments on the LR18 modules. Lower the LR24 array onto the top LR18 module on the Pre rig. You can, of course, also mount individual LR18 modules to the LR24 array. Mount the LR18 front couplers to the inside points of the CNVB1824 and pin it. Take out the LR18 angle arm and mount it to the rear mounting point of the CNVB1824 and pin with the red pin through the slot of the angle arm. Raise the LR24 array and make the necessary cable connections.

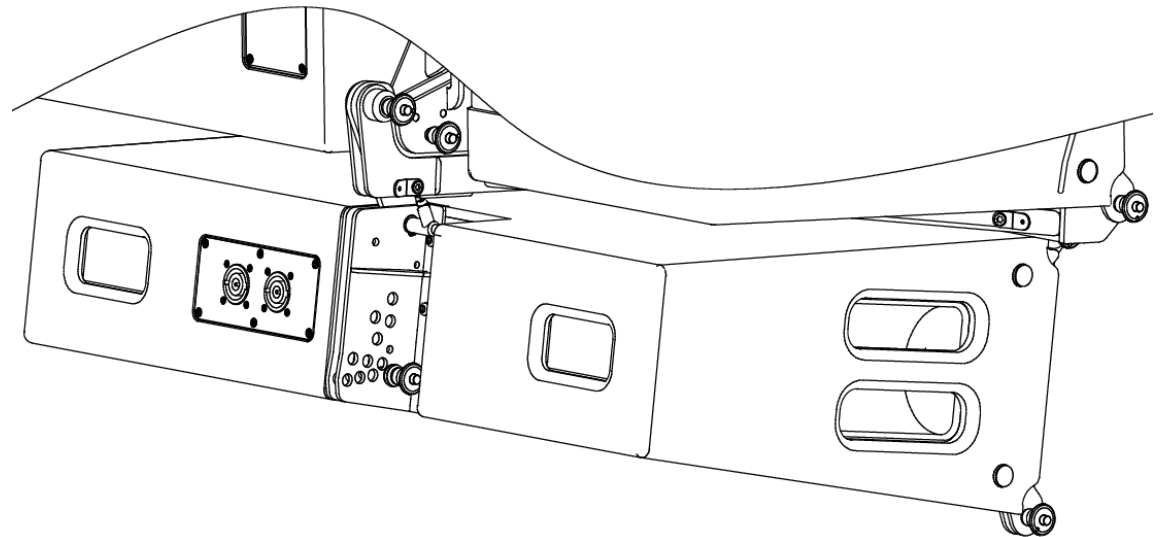

5. Array configurations

Ground stacking PRRG

This description features a 4 piece ground stacked array on a PRRGL24. This is the preferred way of stacking which requires no manual lifting.



Make sure that the array is assembled on a flat and stable surface

Begin by positioning PRRGL24 to the desired location. Ensure that the centre of gravity will be well within the mounting base. This can be determined by the Alcons Ribbon Calculator™ simulation program.

In most cases a pack of LR24's is sufficient. In this case the system will be in compression mode, with the red pins on the angle frame. Set all angles to the desired setting.

Mount the stack feet to each corner of the PRRGL24. The slide tube can be inserted in both ends of the stack foot base bracket and is then locked with a pin at the desired length position. In this way a left or right assembly can be made.

Turn the levelling foot down to the ground plane.

Hold or push the LR24 cabinets in their vertical position and pull out the red pin on the bottom cabinet. **This is a two man job.**

Let the cabinets compress again until the angle is reached. Work your way up.

If the stacked pre-rig needs to be level, turn the levelling feet down to where there is no more slack in the assembly. It is not necessary to lift the entire PRRGL24 off the ground

When the complete angled array needs to be tilted, adjust the levelling feet accordingly and use the front or back castor wheels as pivoting point so they will take much of the weight.



5. Array configurations

Ground stacking GRD24B

This description features a 4 piece ground stacked array on a GRD24B (e).



Make sure that the array is assembled on a flat and stable surface

Begin by positioning the GRD24B at the desired location. Ensure that the centre of gravity will be well within the mounting base. This can be determined by the Alcons Ribbon Calculator™ simulation program. Start disassembling an LR24 pack on a PRRGL24 or use single LR24's. Turn the cabinets 180° in the vertical plane and connect the first one to the GRD24B. You can choose between a 0° or -2.7° angle between LR24 and GRD24B. The system needs to be in compression mode. Set all angles to the desired setting using the Compression fly slot. **This is a two man job.**



6. Service and support

Warranty

Summary

Alcons Audio BV warrants the original purchaser and any subsequent owner of each new Alcons product, for a period of six years limited, electronics 3 years limited, from the date of the original purchase by the original purchaser that the new Alcons product is free of defects in materials and workmanship. Alcons Audio BV warrants the new Alcons product regardless of the reason for failure, except as excluded in this warranty. In order to obtain warranty, you must keep the original sales receipt to establish the exact date of purchase.

Items excluded from warranty

Warranty does not cover any product which has been damaged because of any misuse, accident, or negligence. Warranty also does not extend to a new Alcons product if the serial number has been defaced, altered or removed.

What we will do

Alcons Audio BV will replace defective parts and repair malfunctioning products, regardless of the reason for failure (except as excluded). Warranty work can only be performed at our authorized service centres, or at our factory.

Disclaimer

Alcons Audio BV is not liable for any damage to loudspeakers, amplifiers, or any other equipment that is caused by negligence, misuse or improper installation. Alcons Audio BV is not liable for any incidental damages resulting from any defect in the new Alcons product. This includes any damage to another product or products resulting from such a defect.

Alcons Audio BV reserves the right to change specifications without notice.

6. Service and support

Contact information

Mailing address:

Alcons Audio BV
De Corantijn 69
1689 AN ZWAAG
The Netherlands

Telephone:

+31 (0)229 283090

World Wide Web:

<http://www.alconsaudio.com>

E-mail:

info@alconsaudio.com



7. EC declaration of conformity

Alcons Audio BV
De Corantijn 69
1689 AN ZWAAG
The Netherlands

States that the following products:
LR24 Rigging System

are in conformity with the provisions of the following EC directives and applicable amendments:

Machinery 2006/42/EC

and the national laws to enforce this directive,

National standards and technical specifications applied: *DIN EN ISO 12 100, DIN EN 1050, BGV C1*

provided the mounting components are unaltered/modified and in "factory-original" condition.

Established at Zwaag, the Netherlands,
Jan 21th, 2020

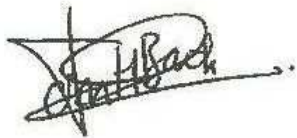

T.H. Back
Managing Director



Notes

